

Balustrade System Installation Manual

Note: Read this step by step instruction manual in it's entirety prior to beginning assembly!
 Read each step in it's entirety beginning each step of assembly!

Step 1: Post Installation

Required tools: screw driver, pencil, 3/4 dia concrete drill bit for installation over concrete.

Place newel post in position on flooring as specified on architectural plans and as adjusted by field measurements. Center newel post accordingly. Mark flooring around edges of newel post. Put newel post aside until later.

A,- Installation over wood flooring: (see figure 1A)

-fasten iron flange for 1" pipe, with appropriate wood screws, in the center of the area marked for the newel post.

Thread 1" steel pipe into the iron flange. Note: pipe length should be approximately 1/2 height of the newel post.

B,- Installation over concrete flooring:(see figure 1B)

-Drill (2) 3/4 dia holes x 3" deep in concrete, centered 4" apart, in the area marked for the newel post.

Insert reinforcement rod . Note: rod length is approximately 1/2 height of the newel post.

Align newel post as marked on deck. Pour light weight concrete to a level approximately 1/3 the height of the newel post.

Do not place newel caps on posts until hand rails are installed.

Tip: If there is a concern of the alignment or accuracy of the entire assembly, pour light weight concrete between steps 8 and 9. This will enable a final adjustment & alignment.

Figure 1A

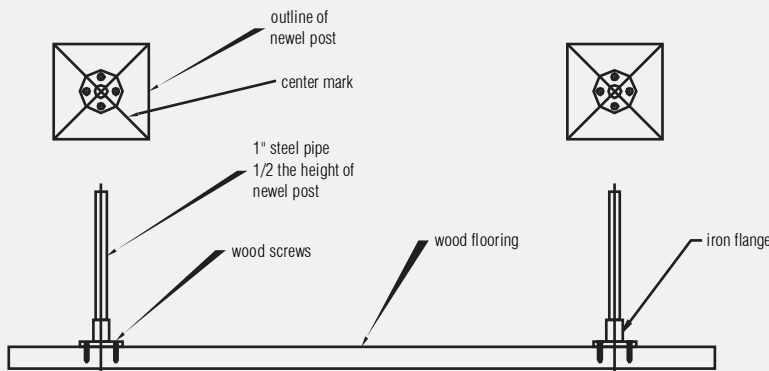
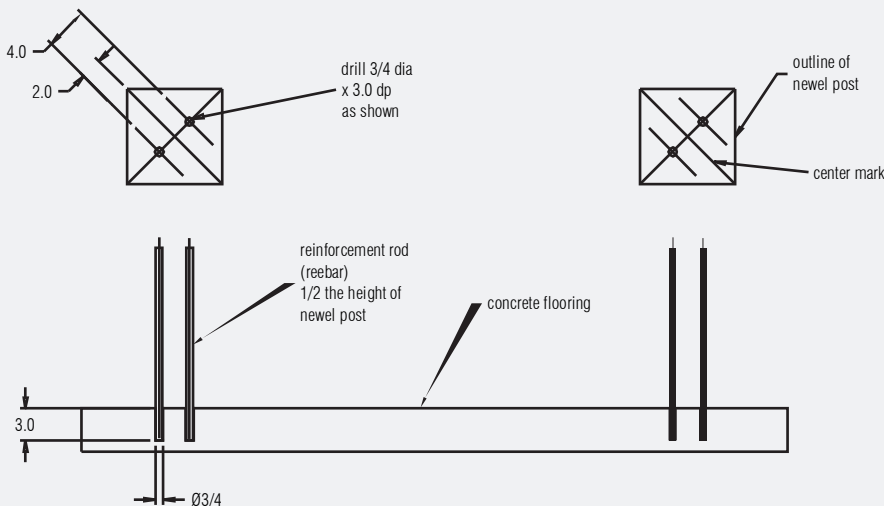

Figure 1B



Step 2: Bottom and top rail preparation

Required tools: circular saw, and carbide or diamond saw blade.

Use carbide saw blade or diamond disc. Cut rails $3/8$ " shorter than measured distance between newel posts.

See figure 2

Figure 2

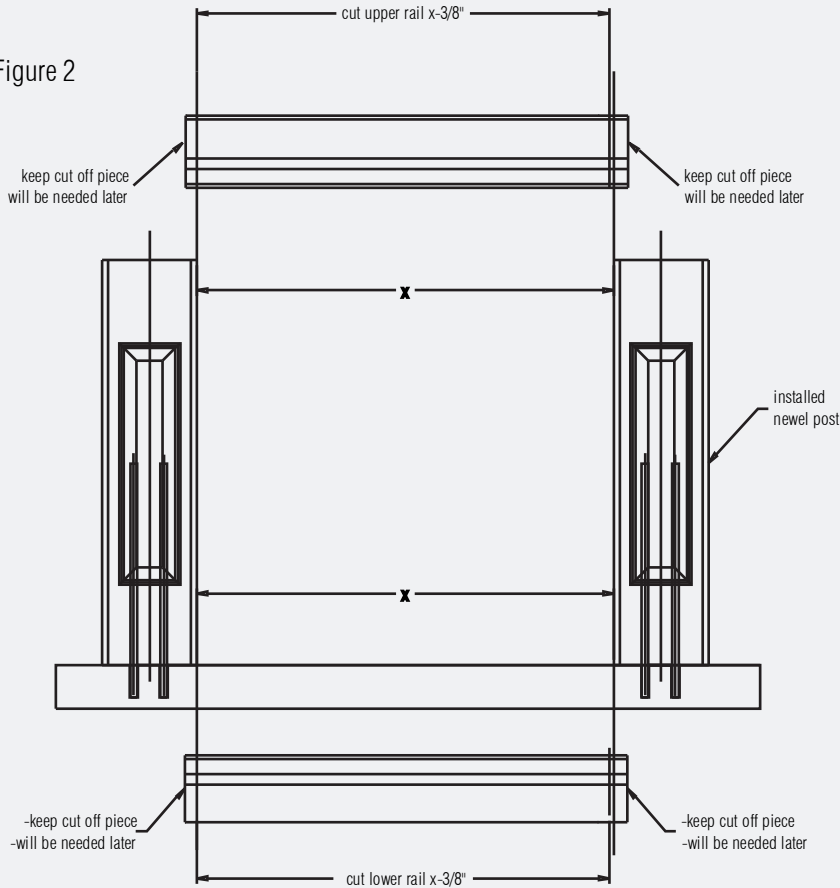

Step 3: Drilling of holes in rails

Tools required: drill, 1 1/8" dia with 1/4 dia pilot hole saw, pencil

Note: Check baluster spacing with blueprint and municipal code before proceeding.

-6" (sphere) spacing: (see figure 3)

Mark the first hole on each side, 4" to 6" from each end, divide the remaining space between the 2 end holes equally. The center distances must be between 6.5" and 8.5" for each baluster. (baluster# 0210, 0210-1, 0214, 0209 and 0219) Space between baluster centers may not exceed 7.5" for baluster# 0225.

-4" (sphere) spacing:

Mark the first hole on each side, 4" to 6" from each end, divide the remaining space between the 2 end holes equally. The center distances may not exceed 6.5".

Tip: During hole drilling rotate drill few degrees to ease cut out removal from tool.

Figure 3

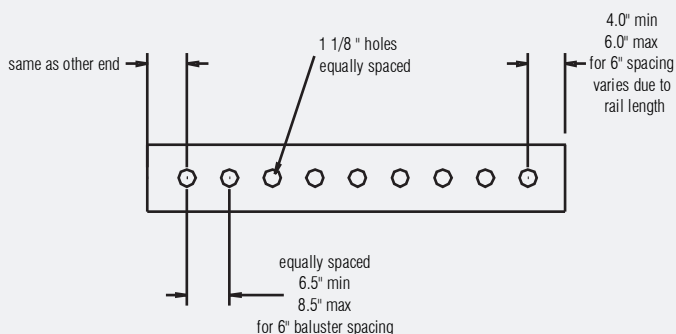

Step 4: Newel post holes for rail connection

Required tools: drill, 5/8" dia carbide drill bit, level and pencil.

Install rail spacers at 2 ft spacing if necessary. Position lower rail between newel posts. Install 2 balusters into pre drilled side holes. Level bottom rail, install, position and level upper rail.

Scribe rail outlines on newel post. (at all 4 rail ends) Remove rails & balusters. (see figure 4A).

Using rail end cut off pieces, match scribed outlines and transfer holes into newel posts, using 5/8" dia carbide drill bit.

Note: It is always the best practice drill 2 holes diagonal to each other (see figure 4B).

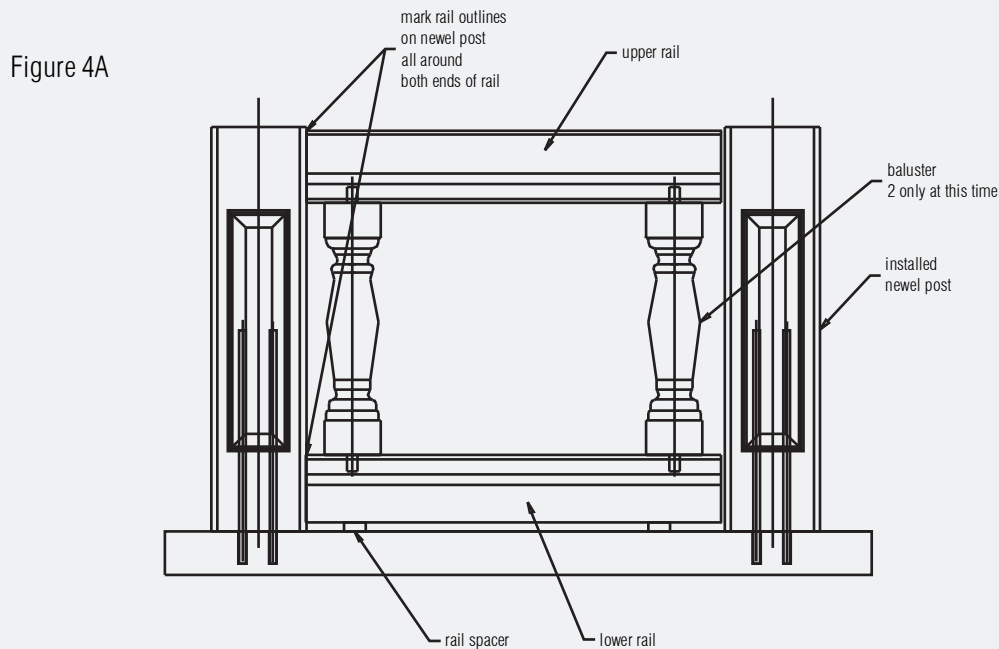

Figure 4B

lower rail

upper rail



best practice:
transfer
diagonal holes
using 5/8" dia
carbide drill bit



best practice:
transfer
diagonal holes
using 5/8" dia
carbide drill bit

Step 5: Spring loaded pin installation

Inspect pvc pipe ends. Clean ends, if necessary, using a round file. Do not force pin into pipe!

Insert steel pin into open end of spring. Insert this spring loaded pin assembly into 2 of the small holes matching the holes drilled into the newel posts. If bracket becomes jammed, slowly turn pin clockwise and gently push (see figure 5).

Figure 5

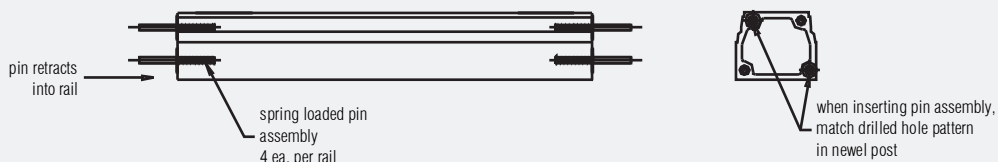

Step 6: Installation of bottom rail

Accessories required: general construction adhesive, wood shims

Place rail spacers, if used, at approximately 2 ft spacing from each other. Apply glue. Under 4 ft post distance, use at least 2 spacers. Place general construction adhesive inside holes at bottom of newel post prior to placement and installation of bottom rail. Place rail to have 3/16 gap at each end. Use wooden shims to lock rail into position until glue hardens (see figure 6).

Figure 6

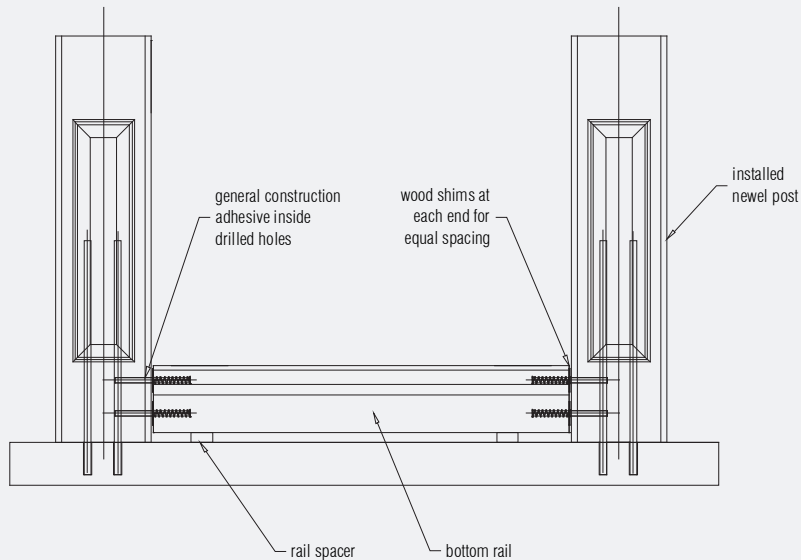

Step 7: Positioning the balusters on the bottom rail

Accessories required: general construction adhesive

Place general construction adhesive 1/2" around pre drilled holes of bottom rail.

Insert and carefully position balusters into holes.

Note: Be sure glue does not squeeze out when positioning the balusters (see figure 7).

Figure 7

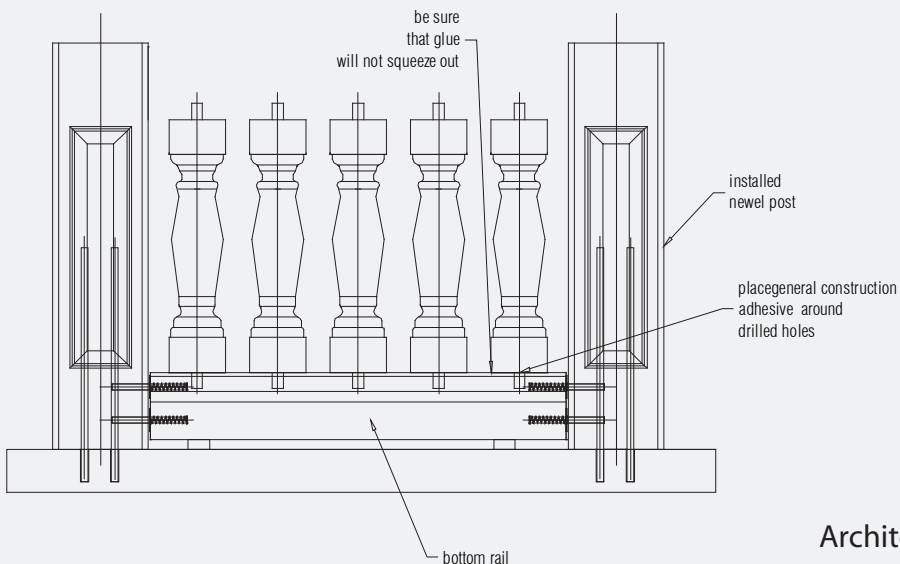

Step 8: Installation of top rail

Accessories required: general construction adhesive

Place general construction adhesive around connecting pipes on top of baluster.

One person should hold the top rail while the other person positions the baluster pipes into holes in top rail. Place rail to have 3/16 gap at each end. Use wooden shims to lock rail into position until glue hardens.

Note: Be sure glue does not squeeze out when positioning the balusters (see figure 8).

Figure 8

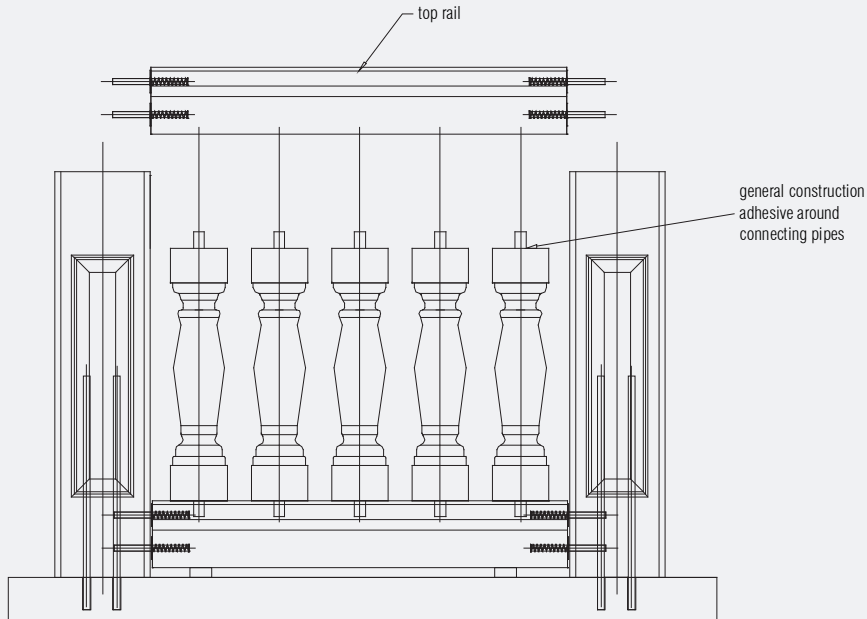

Step 9: Installation of newel post caps

Accessories required: general construction adhesive

Use general construction adhesive to glue post caps on newel posts. Center cap over newel post.

(see figure 9)

Figure 9

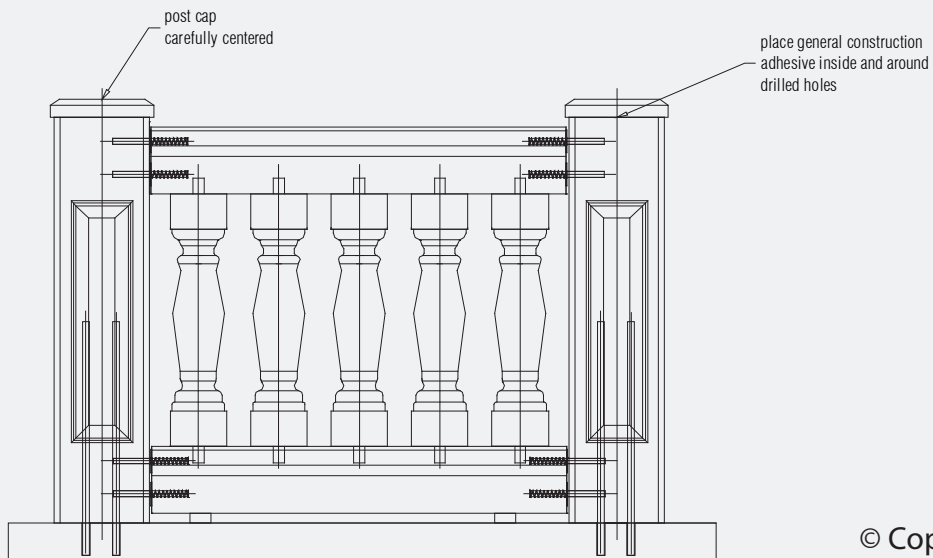

Step 10: Cleaning

Accessories required: soap, brush, and fine grain sand paper.

Clean balustrade system only if needed. Use soap and brush.

Gently use fine grain sand paper if necessary.

Step 11: Caulking

Accessories required: matching color silicone caulk.

Important: Do not let any water to stay inside anywhere in the balustrade system, especially before freezing temperature.

If installation is not complete before end of day, cover system with tarp to prevent rain and moisture infiltration.

Cover all joints, with silicone caulk, in the color to match the balustrade.

(see figure 10)

Figure 10

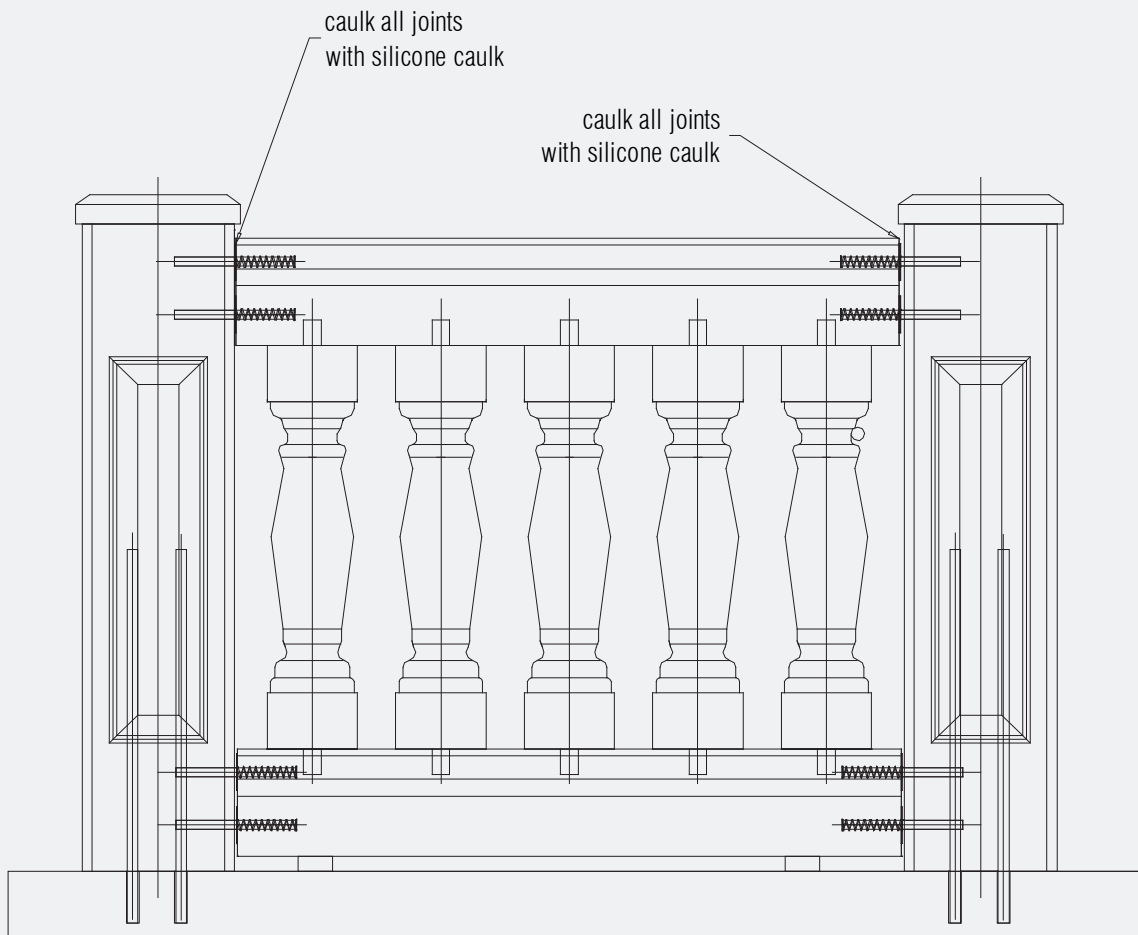

FOR PUBLIC RELEASE